Organizing Data: The Table Structure of a Database



Instructional Design Project

EIST 6110

Dr. Gretes

Spring 1999

Lida Pinkham

Table of Contents

AUDIENCE ANALYSIS.....	2
MODULE DESCRIPTION	3
GOAL ANALYSIS.....	4
FLOW CHART	5
OBJECTIVES.....	6
MATERIALS.....	7
GAGNE'S NINE EVENTS OF INSTRUCTION.....	8
DALE'S CONE OF EXPERIENCE.....	8
INTRODUCTION & PRE-INSTRUCTIONAL ACTIVITIES	9
PRE-REQUISITE SKILLS.....	9
OBJECTIVES	9
MOTIVATION	9
OBJECTIVE #1: IDENTIFY DATA	10
OBJECTIVE 2: IDENTIFY PRIMARY KEY.....	11
OBJECTIVE 3: APPLY FIRST THREE NORMAL FORMS.....	12
OBJECTIVE 4: CREATE RELATIONSHIPS	13
OBJECTIVE 5: IDENTIFY DATA TYPES.....	14
OBJECTIVE 6: IDENTIFY PROPERTY TYPES	15
EVALUATION.....	16
FORMATIVE EVALUATION	16
SUMMATIVE EVALUATION.....	16
TRANSFER OF LEARNING	16
INTRODUCTION TO ACCESS 97 PRE-ASSESSMENT	17
EXERCISES.....	18
VALLE COFFEE EXERCISE.....	18
WALKER DATABASE.....	19
DATABASE DESIGN CHECKLIST	20

Audience Analysis

Subject

Microsoft Access

Unit Topic

Organizing Data: The Table Structure of a Database

Level

Introductory

Goal

Given some information, students will use the first three normal forms to organize the information into separate tables with corresponding relationships, data types, and field properties.

Audience Analysis

The target audience is business professionals who have little or no experience with Microsoft Access. The learners will need good working knowledge of the PC and at minimum should have the following skills: ability to use a mouse & keyboard, run programs, save and open files, format and edit data. In addition to these computer skills the audience should also be familiar with sorting information and creating simple formulas.

An analysis of the audience will need to be conducted. It would be a good idea to find out what the audience already knows about creating databases. This will help determine if the design is starting at the correct level and if any adjustments will need to be made. This can also point out any trouble spots or incorrectly learned habits and/or procedures that will need to be addressed.

Another area to look at is the learning preferences of the audience. In this case, would they prefer to have lecture, hands-on, or a combination of both. Do they like to cover the material and then work individually or work in groups. Or would they rather work through the material together as a class?

Module Description

Subject

Microsoft Access

Unit Topic

Organizing Data: The Table Structure of a Database

Level

Introductory

Goal

Given some information, students will use the first three normal forms to organize the information into separate tables with corresponding relationships, data types, and field properties.

Module Description

A good table structure provides the foundation for a good database. Learning to effectively use Microsoft Access begins with an understanding of how to organize the information correctly so that it can be effectively retrieved. This unit on table structure design will serve as an entry point for an introductory course on Microsoft Access. This unit covers the theory behind creating an Access database. The tables will be created on the computer in the next lesson.

Goal Analysis

Goal

Given some information, students will use the first three normal forms to organize the information into separate tables with corresponding relationships, data types, and field properties.

Goal Analysis

Information Processing	Task Classification	Learning Task
Identify information to be stored	Concrete Concept	<ul style="list-style-type: none"> Gather existing sources of output and list information gathered Break resulting information into smallest possible chunks of data
Select primary key for each table	Problem Solving	<ul style="list-style-type: none"> Group data by entity Create primary key for each entity
Verify that each entity adheres to the first three normal forms	Problem Solving	<ul style="list-style-type: none"> Create new tables for repeating groups within the table Eliminate redundant information Eliminate information that does not depend on the primary key
Create relationships between tables	Problem Solving	<ul style="list-style-type: none"> Create foreign keys in appropriate tables Diagram relationships between foreign keys and primary keys Determine relationship types (one-to-one, one-to-many, and many-to-many) Determine properties of relationships (referential integrity, cascade delete, cascade update)
Determine the data type for each field	Concrete Concept	<ul style="list-style-type: none"> Define the following data types: text, memo, number, date/time, currency, autonumber, yes/no, OLE, and hyperlink Select the appropriate data type for each field
Customize the properties for each field.	Problem Solving	<ul style="list-style-type: none"> Explain the function of the following property types (field size, format, caption, input mask, validation rule, & validation text) Determine which properties need to be set

Flow Chart

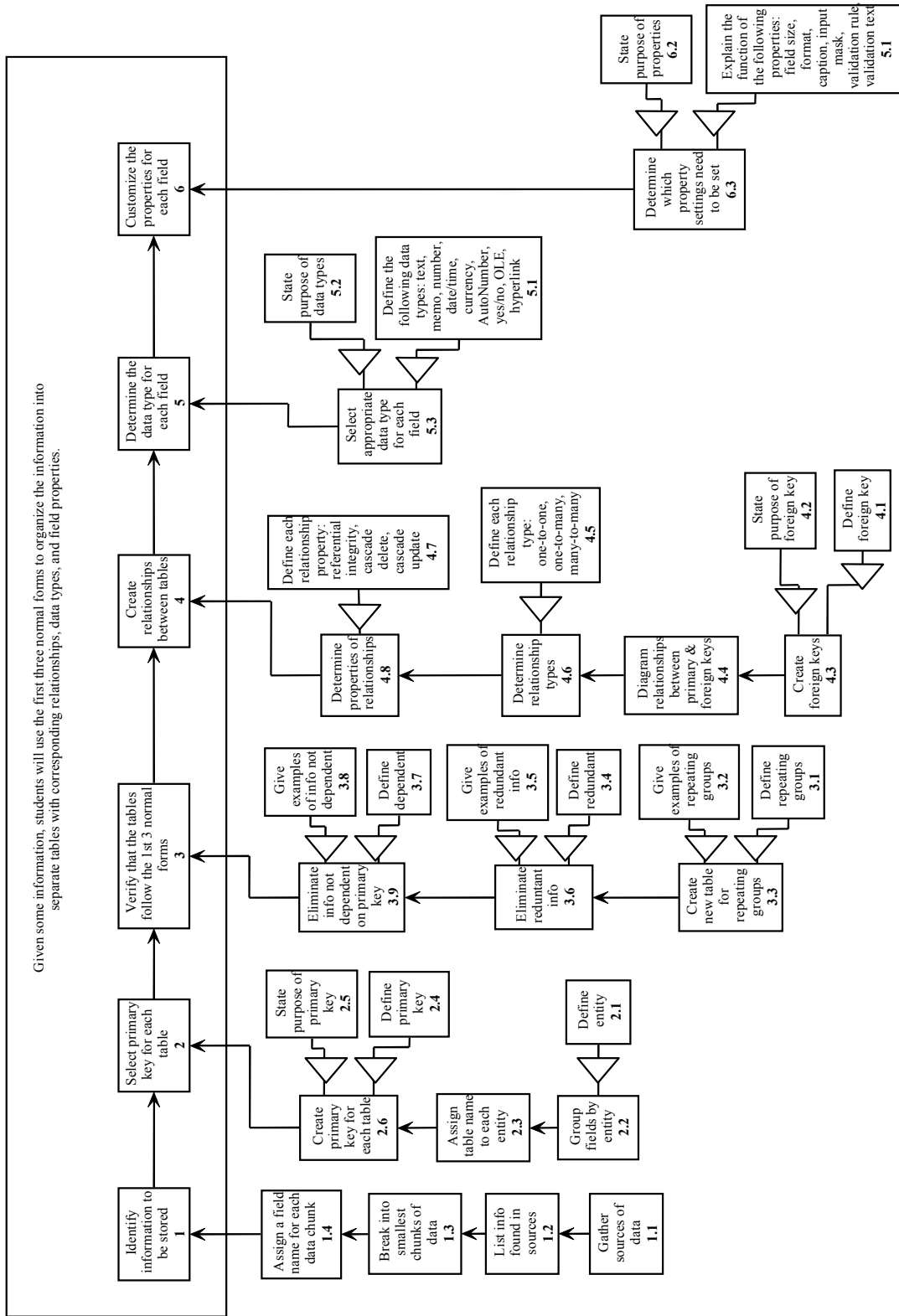

Objectives

Subject

Microsoft Access

Unit Topic

Organizing Data: The Table Structure of a Database

Level

Introductory

Goal

Given some information, students will use the first three normal forms to organize the information into separate tables with corresponding relationships, data types, and field properties.

Objectives

1. Given some reports, students will be able to identify the individual pieces of data to be stored by creating a list of the information on a sheet of paper.
2. Given a list of information, students will be able to generate a primary key by grouping the information into entities using post-it notes and poster board to illustrate groupings.
3. Given several entities, students will be able to generate tables by verifying that each entity adheres to the first three normal forms.
4. Given several tables, students will be able to generate the relationships between tables by creating foreign keys, diagramming the relationships on a sheet of paper, and determining the relationship types and properties according to the definitions of the property types and relationships.
5. Given the fields in a table, students will be able to identify the data types by using the definitions of the following data types: text, memo, date/time, number, currency, yes/no, hyperlink, and OLE.
6. Given the functions of the following property types: field size, format, caption, input mask, validation rules, validation text, students will be able to generate the necessary properties by listing the appropriate information for each property with its corresponding fields.

Materials

- Text: Adamski, Joseph, Hommel, Charles, and Finnegan, Kathleen T. (1998). New Perspectives on Microsoft Access 97 Comprehensive, Cambridge, MA: Course Technology.
- One computer for each student with Microsoft Access and the Northwinds database installed.
- 1 pad of small post-it notes for each student. (Students will use the sticky notes for organizing the fields. One field will be written on each sticky note so that they can be easily arranged.)
- 1 poster board for each student (Students will use this for applying the sticky notes into logical groups.)
- Colored markers (Students will use this to label the tables and draw the relationships between them.)
- Whiteboard and/or chalkboard (Used by the instructor to illustrate concepts)
- One copy of pages 17-20 for each student.

Gagne's Nine Events of Instruction

Use the legend below to identify the Gagne's Nine Events of Instruction found throughout this teaching plan.

- Event 1: Gaining Attention
- Event 2: Informing the Learner of Objectives
- Event 3: Stimulating Recall of Prerequisite Learning
- Event 4: Presenting the Stimulus Material
- Event 5: Providing Learner Guidance
- Event 6: Eliciting Performance
- Event 7: Providing Feedback
- Event 8: Assessing the Performance
- Event 9: Enhancing Retention & Transfer

Dale's Cone of Experience

Use the legend below to identify the Dale's Cone of Experience applied throughout this teaching plan.

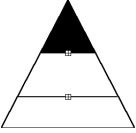
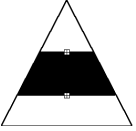
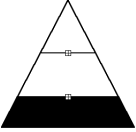
<p>Abstract Level</p> 	<p>Verbal Symbols</p> <p>Visual Symbols</p>	<p>Involve symbolizing in order of increasing abstractness</p>
<p>Semi-Abstract Level (Iconic)</p> 	<p>Radio, Recordings, Still Pictures</p> <p>Watch Moving Pictures</p> <p>Watch an Exhibit</p> <p>Watch a Demonstration</p>	<p>Involve observing in order of decreasing directness</p>
<p>Concrete Level (Direct-Purposeful)</p> 	<p>Dramatic Participation</p> <p>Contrived Experiences</p> <p>Direct Experience</p>	<p>Involve doing in order of decreasing directness</p>

Introduction & Pre-instructional Activities

Instruction	Dale's Cone	Gagne's Event
<p>Pre-requisite Skills</p> <p>Students will fill out pre-requisite skills checklist as a self-assessment (p.17). Students who do not have all of the pre-requisite skills will be referred to the appropriate classes to obtain those skills.</p>		3
<p>Objectives</p> <p>Review objectives with the class.</p>		2
<p>Motivation</p> <p>Students will share what they hope to achieve by taking this course.</p>		1

Objective #1: Identify Data

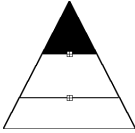
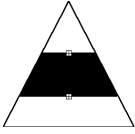
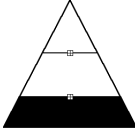
Instruction	Dale's Cone	Gagne's Event
<p>Information</p> <ul style="list-style-type: none"> Discuss relational databases: what they are, what they are used for, and the importance of good logical design. Briefly highlight the overall strategy for designing the table structure for a database. 		4
<p>Examples</p> <ul style="list-style-type: none"> Look at the sample "Northwinds" database that comes with Microsoft Access. Look at the different tables in the database and how they are related. 		5
<p>Practice Items</p> <ul style="list-style-type: none"> Break students into groups of 2 or 3. Using the Valle Coffee reports found on p. 18, students will list all the different pieces of information found on those reports that would need to be stored in a database. 		6
<p>Feedback</p> <ul style="list-style-type: none"> Review students' answers and make corrections/suggestions where necessary. 		7

Objective 2: Identify Primary Key

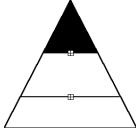
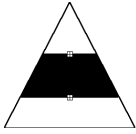
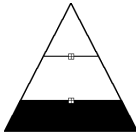
Instruction	Dale's Cone	Gagne's Event
<p>Information</p> <ul style="list-style-type: none"> • Discuss the definition of an entity • Explain the purpose of a primary key. 		4
<p>Examples</p> <ul style="list-style-type: none"> • Look at the entities and primary keys in the Northwinds database. 		5
<p>Practice Items</p> <ul style="list-style-type: none"> • Groups will write each field obtained in previous exercise onto a separate post-it note. • Post-it notes will then be grouped into logical entities (or groupings) onto the poster board. Using a marker the students should label each grouping. • Groups will then assign primary keys to each entity that was created. The primary key should be written on a post-it note and then placed with their appropriate groups. 		6
<p>Feedback</p> <ul style="list-style-type: none"> • Review groupings & primary keys created by students and discuss pros & cons of groupings. 		7

Objective 3: Apply First Three Normal Forms

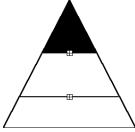
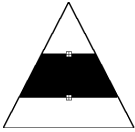
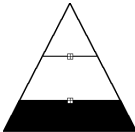
Instruction	Dale's Cone	Gagne's Event
<p>Information</p> <ul style="list-style-type: none"> Explain the first three normal forms 		4
<p>Examples</p> <ul style="list-style-type: none"> Look at how these 3 normal forms are applied in the Northwinds database 		5
<p>Practice Items</p> <ul style="list-style-type: none"> Groups will examine entities to see if groupings adhere to the first three normal forms and rearrange the post-it notes to demonstrate any new groupings. 		6
<p>Feedback</p> <ul style="list-style-type: none"> Discuss decisions made by groups and make corrections where necessary 		7

Objective 4: Create Relationships

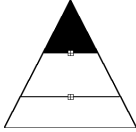
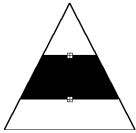
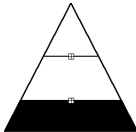
Instruction	Dale's Cone	Gagne's Event
<p>Information</p> <ul style="list-style-type: none"> • Discuss relationships between tables and the use of foreign keys to create these relationships. • Discuss the different types of relationships and the properties of those relationships. 		4
<p>Examples</p> <ul style="list-style-type: none"> • Look at the relationships and foreign keys in the Northwinds database. 		5
<p>Practice Items</p> <ul style="list-style-type: none"> • Groups will create the relationships between tables and diagram them on the poster board. • Groups will determine the type and properties of created relationships and label diagram appropriately. 		6
<p>Feedback</p> <ul style="list-style-type: none"> • Review relationships created by the groups. 		7

Objective 5: Identify Data Types

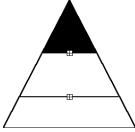
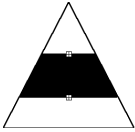
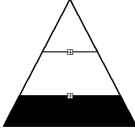
Instruction	Dale's Cone	Gagne's Event
<p>Information</p> <ul style="list-style-type: none"> Discuss the different data types 		4
<p>Examples</p> <ul style="list-style-type: none"> Text p. 2.4-2.6 Northwinds database 		5
<p>Practice Items</p> <ul style="list-style-type: none"> Groups will write data types for all fields on the post-it notes. 		6
<p>Feedback</p> <ul style="list-style-type: none"> Review choices made by groups and ask them to justify their selections 		7

Objective 6: Identify Property Types

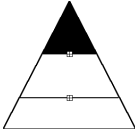
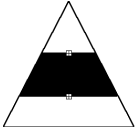
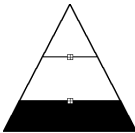
Instruction	Dale's Cone	Gagne's Event
<p>Information</p> <ul style="list-style-type: none"> Discuss the different property types 		4
<p>Examples</p> <ul style="list-style-type: none"> Text p. 2.7-2.11 Northwinds database 		5
<p>Practice Items</p> <ul style="list-style-type: none"> Groups will assign properties to appropriate fields in the tables and write these on the corresponding post-it notes. 		6
<p>Feedback</p> <ul style="list-style-type: none"> Review choices made by groups and ask them to justify their selections 		7

Evaluation

Instruction	Dale's Cone	Gagne's Event
<p>Formative Evaluation</p> <p>Each objective has a practice exercise that students will work on together as groups. The instructor will review the work done by the students and use this as a guide to whether or not more instruction is necessary on that particular objective.</p>		8
<p>Summative Evaluation</p> <p>Students will be given the Walker Database report on page 19 and asked to design the table structure for this database based on the procedure they learned in class. This exercise will help determine if student is able to put all of the steps together to design a table structure.</p> <p>The instructor will review the database design using the Database Design Checklist found on page 20. Designs will be returned to students with this checklist and a correctly completed design to which they can compare their own design. Students will be given the opportunity to ask questions.</p>		9
<p>Transfer of Learning</p> <p>It is important that students can transfer their skills to their jobs. Each student will be asked to think about how Access can help them manage information in their jobs. They then will be required to design the table structure for that database. This will provide the foundation for the database that students will create on their own as they progress through this introductory course on Microsoft Access. The instructor will be available by phone or email for assistance.</p>		9

Introduction to Access 97 Pre-assessment

Name _____

Please rate your confidence in the following skills:

Skill	No Experience	Need Review	No Review Needed
Using a mouse	<input type="checkbox"/>	<input type="checkbox"/>	<input type="checkbox"/>
Using the keyboard	<input type="checkbox"/>	<input type="checkbox"/>	<input type="checkbox"/>
Starting programs	<input type="checkbox"/>	<input type="checkbox"/>	<input type="checkbox"/>
Saving files	<input type="checkbox"/>	<input type="checkbox"/>	<input type="checkbox"/>
Opening files	<input type="checkbox"/>	<input type="checkbox"/>	<input type="checkbox"/>
Formatting text	<input type="checkbox"/>	<input type="checkbox"/>	<input type="checkbox"/>
Editing text	<input type="checkbox"/>	<input type="checkbox"/>	<input type="checkbox"/>
Sorting information in a list	<input type="checkbox"/>	<input type="checkbox"/>	<input type="checkbox"/>
Creating simple formulas	<input type="checkbox"/>	<input type="checkbox"/>	<input type="checkbox"/>

Briefly describe your current experience with Microsoft Access and/or database design

Explain what you hope to be able to do after taking this course

Exercises

Valle Coffee Exercise

Design a database that will help Valle Coffee keep up with customer orders. Use the reports below to help you design the table structure.

Report 1: Customer Analysis

CustomerNum	CustomerName	City	OwnerName	FirstContact
104	Meadows Restaurant	Monroe	Mr. Ray Suchecki	2/28/91
107	Cottage Grill	Bootjack	Ms. Doris Reaume	4/3/91
122	Roadhouse Restaurant	Clare	Ms. Shirley Woodruff	4/12/91
123	Bridge Inn	Ada	Mr. Wayne Bouwman	4/17/91

Report 2: Customer List

CustomerNum	CustomerName	City	State	OwnerName	Phone
650	The Peppermill	Elkhart	IN	Ms. Tara Jerentowski	(219) 334-3980
798	Embers Restaurant	Goshen	IN	Mr. Clifford Merritt	(219) 816-2456
750	Grain Bin Inn	LaPorte	IN	Ms. Bridgit Feeney	(219) 339-1264
741	Prime Cut Steakhouse	Mishawaka	IN	Ms. Gretchen Fletcher	(219) 336-0900
624	South Bend Brewing Company	South Bend	IN	Mr. Toby Stein	(219) 332-4847

Report 3: Customer Orders

CustomerName	City	State	BillingDate	Paid	InvoiceAmt
Meadows Restaurant	Monroe	MI	1/15/99	Yes	1,280.50
Meadows Restaurant	Monroe	MI	2/15/99	Yes	1,323.00
Meadows Restaurant	Monroe	MI	3/15/99	Yes	1,440.50
Cottage Grill	Bootjack	MI	1/15/99	No	854.00
Cottage Grill	Bootjack	MI	2/15/99	Yes	815.00

Walker Database

Noah and Sheila Warnick organize many different Walk-A-Thons for Best Friends. They would like your help in designing a database to help them keep track of the walkers and the collection of their pledges. Use the report below to design the table structure of the database.

Walk-A-Thon Walkers And Pledges

LastName	Zimmerman	Phone	881-7921			
FirstName	Anne	Distance	2.5			
	Pledger	PledgeAmt	PaidAmt	DatePaid	PerMile	
	Fernando Carazana	25.00	25.00	18-Sep-99	0	
LastName	Finch	Phone	711-8293			
FirstName	Syd	Distance	2.3			
	Pledger	PledgeAmt	PaidAmt	DatePaid	PerMile	
	Northwest Industries	23.00	0.00	01-Sep-99	10	
	Target Players	11.50	11.50	20-Sep-99	5	
LastName	Lemieux	Phone	881-3992			
FirstName	Phillipe	Distance	2.0			
	Pledger	PledgeAmt	PaidAmt	DatePaid	PerMile	
	Justin Boyd	5.00	5.00	15-Sep-99	0	

Database Design Checklist

This checklist is used to determine if you have included all of the important elements of database design.

Element	Not Done	Needs Improvement	Complete
1. Fields have been identified. Comments:	<input type="checkbox"/>	<input type="checkbox"/>	<input type="checkbox"/>
2. Identified fields have been grouped into logical entities. Comments:	<input type="checkbox"/>	<input type="checkbox"/>	<input type="checkbox"/>
3. A primary key has been created for each entity. Comments:	<input type="checkbox"/>	<input type="checkbox"/>	<input type="checkbox"/>
4. Each entity follows the first three normal forms			
• Removed Repeating Groups	<input type="checkbox"/>	<input type="checkbox"/>	<input type="checkbox"/>
• Removed Partial Dependencies	<input type="checkbox"/>	<input type="checkbox"/>	<input type="checkbox"/>
• Removed Fields not Dependent on Primary Key	<input type="checkbox"/>	<input type="checkbox"/>	<input type="checkbox"/>
Comments:			
5. Foreign keys have been created and relationships identified. Comments:	<input type="checkbox"/>	<input type="checkbox"/>	<input type="checkbox"/>
6. The data type for each field has been identified. Comments:	<input type="checkbox"/>	<input type="checkbox"/>	<input type="checkbox"/>
7. Properties have been generated for each field as appropriate. Comments:	<input type="checkbox"/>	<input type="checkbox"/>	<input type="checkbox"/>